



de manincor

ITALIAN MASTERPIECES SINCE 1828

CR160

TECHNICAL SHEET

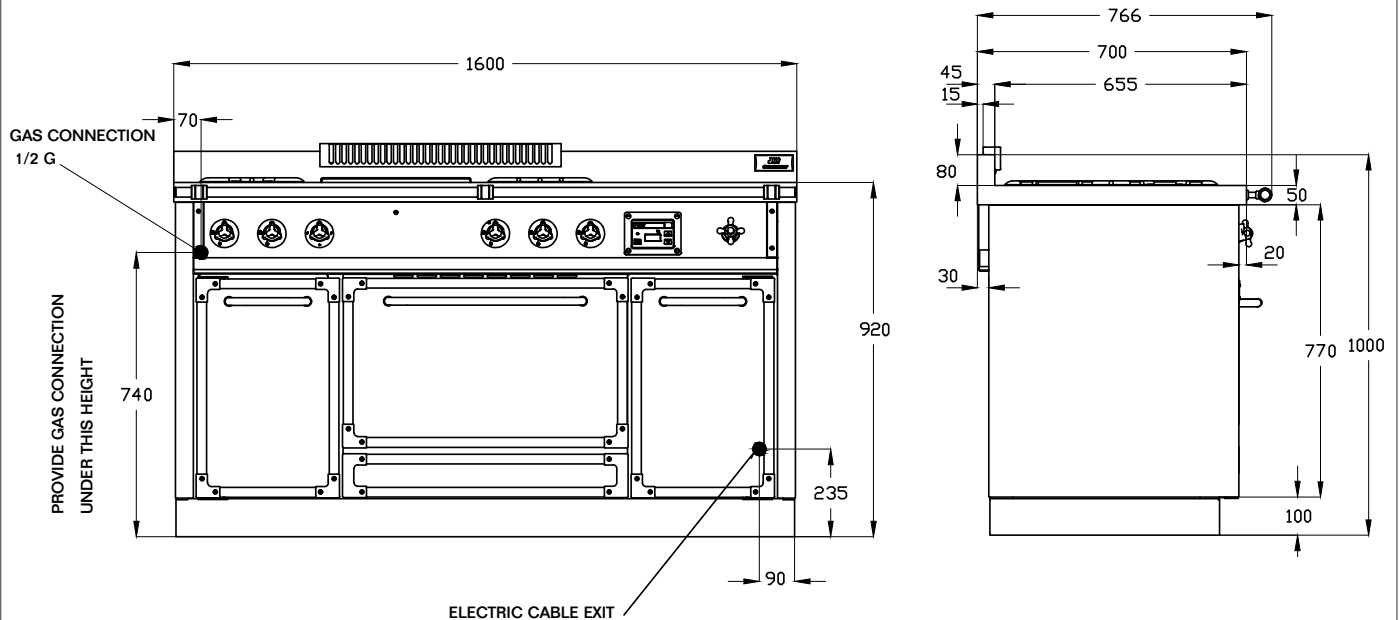

DIMENSIONS: 1600 x 700 x h 920 mm

- EQUIPMENT:**
- Gas burners: 1 x 2 kW/G - 1 x 3 kW/G - 1 x 4 kW/G - 1 x 5 kW/G
 - 5 zone induction hob: 2 x 1.4 kW - 1 x 1.4/2 kW - 1 x 2.3 kW - 1 x 2.3/3 kW
 - 2 zones induction hob: 1 x 1.4/2 kW - 1 x 2.3 kW
 - Electric oven : 605 x 400 x h 335 mm - 2.5 kW 230 V-8 functions
 - horizontal rotisserie, temperature up to max 320 °C
 - blind oven door
 - Drawer under the oven : 660 x 560 x h 80 mm
 - Control compartment : oven cooking functions, oven thermostat, timer, small drawer for worktop cleaning overflows.
 - Electric warmer - useful volume: 350 x 600 x h530 mm - 0.5 kW 230 V

WORKTOP: 2mm-thick stainless steel, gas equipments are in a waterproof basin with a drain into a pullout drawer for easy cleaning, front worktop h 50 mm, front handrail.

net WEIGHT/with packaging: Kg. 240/300